



Wanrooe Medical
Specialize In **electric** Wheelchairs



万容机械有限公司
WANROOE MACHINERY CO., LTD.
张家港市人民东路19号国泰新天地广场1311,1313室
Room1311,1313, Guotai New World Plaza,
No19,East Renmin Road,
Zhangjiagang, Jiangsu, China.
Tel:+86 512 58810860
Fax:+ 86 512 58810663
Email:info@wanrooemed.com
Http://wanrooemed.com



WANROOE ELECTRIC WHEELCHAIRS

万容机械有限公司
WANROOE MACHINERY CO.,LTD

Contents

electric
wheelchairs & scooter

- 01 ● BWHE301
- 02 ● BWHE1801
- 03 ● BWHE1002
- 04 ● BWHE501
- 05 ● BWHE601
- 06 ● BWHE602
- 07 ● BWHE802
- 08 ● BW201
- 09 ● Accessory
- 10 ● Certificate



⊙ **Foldable Backrest**

Push the button, and fold the backrest easily to reduce the space.

⊙ **Intelligent control**

Ingenious, simple, accurate, full-intelligent, easy to operate.

⊙ **Detachable Footrest**

Adjustable and detachable. Good quality heel bands, comfortable and safe.

⊙ **Flip-up Armrest**

Humane design for easy up and down from the wheelchair. PU armpads reduce hand pressure and feel comfortable.

⊙ **Chilwee Battery**

Chinese battery industry leader brand.

⊙ **Motor**

Low noise, stable performance.

⊙ **Clutch**

Unique safety design. Easy to switch between manual and electric function.

⊙ **Anti-tipper**

Avoid wheelchairs tilting over. Small castors can be easily assembled and dismantled.

Electric Wheelchairs

BWHE301 Electric wheelchair











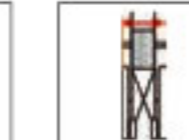

Features

Both manual and power operation modes; Foldable and portable; Removable battery box for convenient recharging; Flip-up armrest, adjustable and detachable footrest; Control can be exchanged from right side to left side for both hands use; Rear wheel drive by two motors; Easy to operate, dismantle and assembling; Solid front tires, pneumatic rear tires.

Parameters

- ⊙ **Driving range:** 15-20km
- ⊙ **Max speed:** 6km/h
- ⊙ **Motor:** DC 250W *2Pcs
- ⊙ **Battery:** 12V 12AH/20AH *2Pcs
- ⊙ **Parking brake:** manual brake
- ⊙ **Frame material:** steel
- ⊙ **Frame color:** silver, blue, black, red

 N.W. (kg)	 overall length(mm)	 overall width(mm)	 folded width(mm)	 seat width(mm)	 rear wheel(inch)
40	1090	685	420	450	22
 front wheel(inch)	 seat height (mm)	 overall height(mm)	 seat depth(mm)	 backrest height(mm)	 loading capacity(kg)
8	500	930	435	395	100

BWHE1801 Electric wheelchair















Features

Foldable and portable; Removable battery box for convenient recharging; Flip-up armrest, adjustable and detachable footrest; Control can be exchanged from right side to left side for both hands use; Rear wheel drive by two motors; Easy to operate, dismantle and assembling; Pneumatic front tires and rear tires, more comfortable.

Parameters

- ⊙ **Driving range:** 15-20km
- ⊙ **Max speed:** 6km/h
- ⊙ **Motor:** DC 250W *2Pcs
- ⊙ **Battery:** 12V 12AH/20AH *2Pcs
- ⊙ **Parking brake:** manual brake
- ⊙ **Frame material:** steel
- ⊙ **Frame color:** silver, blue, black, red

 N.W. (kg)	 overall length(mm)	 overall width(mm)	 folded width(mm)	 seat width(mm)	 rear wheel(inch)
44	1110	635	380	450	18
 front wheel(inch)	 seat height (mm)	 overall height(mm)	 seat depth(mm)	 backrest height(mm)	 loading capacity(kg)
10	525	965	435	395	100

Electric Wheelchairs

BWHE1002 Electric wheelchair



Features

Foldable and portable; Removable battery box for convenient recharging; Flip-up armrest, adjustable and detachable footrest; Control can be exchanged from right side to left side for both hands use; Rear wheel drive by two motors; Easy to operate, dismantle and assembling; Solid front tires, pneumatic rear tires.

Parameters

- ⊙ **Driving range:** 15-20km
- ⊙ **Max speed:** 6km/h
- ⊙ **Motor:** DC 250W *2Pcs
- ⊙ **Battery:** 12V 20AH *2Pcs
- ⊙ **Parking brake:** manual brake
- ⊙ **Frame material:** steel
- ⊙ **Frame color:** silver, blue, black, red

46	1140	640	370	450	12
8	500	935	435	395	100

BWHE501 Electric wheelchair



Features

Foldable and portable; Full-automatic electromagnetic brakes; Removable battery box for convenient recharging; Flip-up armrest, adjustable and detachable footrest; Control can be exchanged from right side to left side for both hands use; Rear wheel drive by two motors; Easy to operate, dismantle and assembling; Solid front tires, pneumatic rear tires.

Parameters

- ⊙ **Driving range:** 15-20km
- ⊙ **Max speed:** 6km/h
- ⊙ **Motor:** DC 250W *2Pcs
- ⊙ **Battery:** 12V 20AH *2Pcs
- ⊙ **Parking brake:** electromagnetic brakes
- ⊙ **Control:** PG; Dynamic controls
- ⊙ **Frame material:** steel
- ⊙ **Frame color:** silver, blue, black, red

49	1170	620	370	450	12
8	500	940	435	395	100

Electric Wheelchairs

BWHE601 Electric wheelchair



Features

Full-automatic electromagnetic brakes; Backrest angle and armrest height are adjustable; Removable battery box for convenient recharging; Quickly removable footrest and armrest; Control can be exchanged from right side to left side for both hands use; Rear wheel drive by two motors; Easy to operate, dismantle and assembling; Both front and rear pneumatic tires

Parameters

- ⊙ **Driving range:** 15-20km
- ⊙ **Max speed:** 6km/h
- ⊙ **Motor:** DC 250W *2Pcs
- ⊙ **Battery:** 12V 20AH *2Pcs
- ⊙ **Parking brake:** electromagnetic brakes
- ⊙ **Control:** PG; Dynamic controls
- ⊙ **Frame material:** steel
- ⊙ **Frame color:** silver, blue, black, red

N.W. (kg)	overall length(mm)	overall width(mm)	folded width(mm)	seat width(mm)	rear wheel(inch)
61	1010	600	n/a	450	12
front wheel(inch)	seat height (mm)	overall height(mm)	seat depth(mm)	backrest height(mm)	loading capacity(kg)
8	490	1075	450	480	100

BWHE602 Electric wheelchair



Features

Aluminum frame, lightweight; Foldable and portable; Full-automatic electromagnetic brakes; Removable battery box for convenient recharging; Flip-up armrest, adjustable and detachable footrest; Control can be exchanged from right side to left side for both hands use; Rear wheel drive by two motors; Easy to operate, dismantle and assembling; Solid front tires, pneumatic rear tires.

Parameters

- ⊙ **Driving range:** 15-20km
- ⊙ **Max speed:** 6km/h
- ⊙ **Motor:** DC 250W *2Pcs
- ⊙ **Battery:** 12V 20AH *2Pcs
- ⊙ **Parking brake:** electromagnetic brakes
- ⊙ **Control:** PG; Dynamic controls
- ⊙ **Frame material:** Aluminum alloy
- ⊙ **Frame color:** silver, blue, black, red

N.W. (kg)	overall length(mm)	overall width(mm)	folded width(mm)	seat width(mm)	rear wheel(inch)
43	1060	610	320	450	12
front wheel(inch)	seat height (mm)	overall height(mm)	seat depth(mm)	backrest height(mm)	loading capacity(kg)
8	490	940	430	395	100

Electric Wheelchairs

BWHE802 Mobility Scooter



Features

Both manual and power operation modes; Foldable and portable; Flip-up armrest, adjustable armrest width and seat height; Standard light backrest; Foldable sponge cushion; Rotatable base for convenient up and down from the scooter; 9 inch pneumatic tires.

Parameters

- ⊙ **Driving range:** 15-20km
- ⊙ **Max speed:** 6km/h
- ⊙ **Motor:** DC 180W
- ⊙ **Battery:** 12V 20AH *2Pcs
- ⊙ **Parking brake:** electromagnetic brakes
- ⊙ **Control:** intelligent control panel

N.W. (kg) 55	overall length(mm) 1160	overall width(mm) 520	folded width(mm) n/a	seat width(mm) 420	rear wheel(inch) 9
front wheel(inch) 9	seat height (mm) 565	overall height(mm) 990	seat depth(mm) 390	backrest height(mm) 380	loading capacity(kg) 100

BW201 Aluminum wheelchair



Features

Deluxe aluminum wheelchair, liquid painted frame, flip back armrest with PU arm pad, quick detachable footrest, alum front fork, high strength alum folding back, black and red double layers nylon upholstery with easily taken off outer layer for wash and cleaning, 8" front PU castor, 24" quick release rear spoke wheel with solid PU tire and alum hand rim, black brake, plastic side panel and footplate with heel loop, with anti-tipper.

N.W. (kg) 15.9	overall length(mm) 990	overall width(mm) 640	folded width(mm) 360	seat width(mm) 450	rear wheel(inch) 24
front wheel(inch) 8	seat height (mm) 500	overall height(mm) 945	seat depth(mm) 447	backrest height(mm) 395	loading capacity(kg) 130

Electric Wheelchairs

Accessory



PG control

International brand electric wheelchair control. High quality, more stable performance, easier operation, more comfortable experience.



Dynamic control

New Zealand brand electric wheelchair control. High quality, more stable performance, easier operation, more comfortable experience.



Thick gel cushion

Made of HR+GEL integration. With cooling function, prevent pressure ulcers. Size: 420*420*30mm



Thin gel cushion

Made of HR+GEL integration. With cooling function, prevent pressure ulcers. Size: 450*430*5mm



Gel cushion

Made of 3 layers HR+LR+GEL, with air permeable and water resistant nylon fabric cover. Comfortable and prevent pressure ulcers. Size: 400*420*70mm

Certificate

